

MOT. 352.913 | 916 | 918 | 937 | 946 | 949 | 950 | 968 | 988 | 994
MOT. 353.909-914 | 950-954 | 970-972 | 974 | 975 | 978 | 991 | 997

OM 352 A Mercedes-Benz –

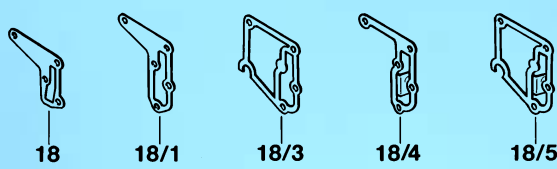

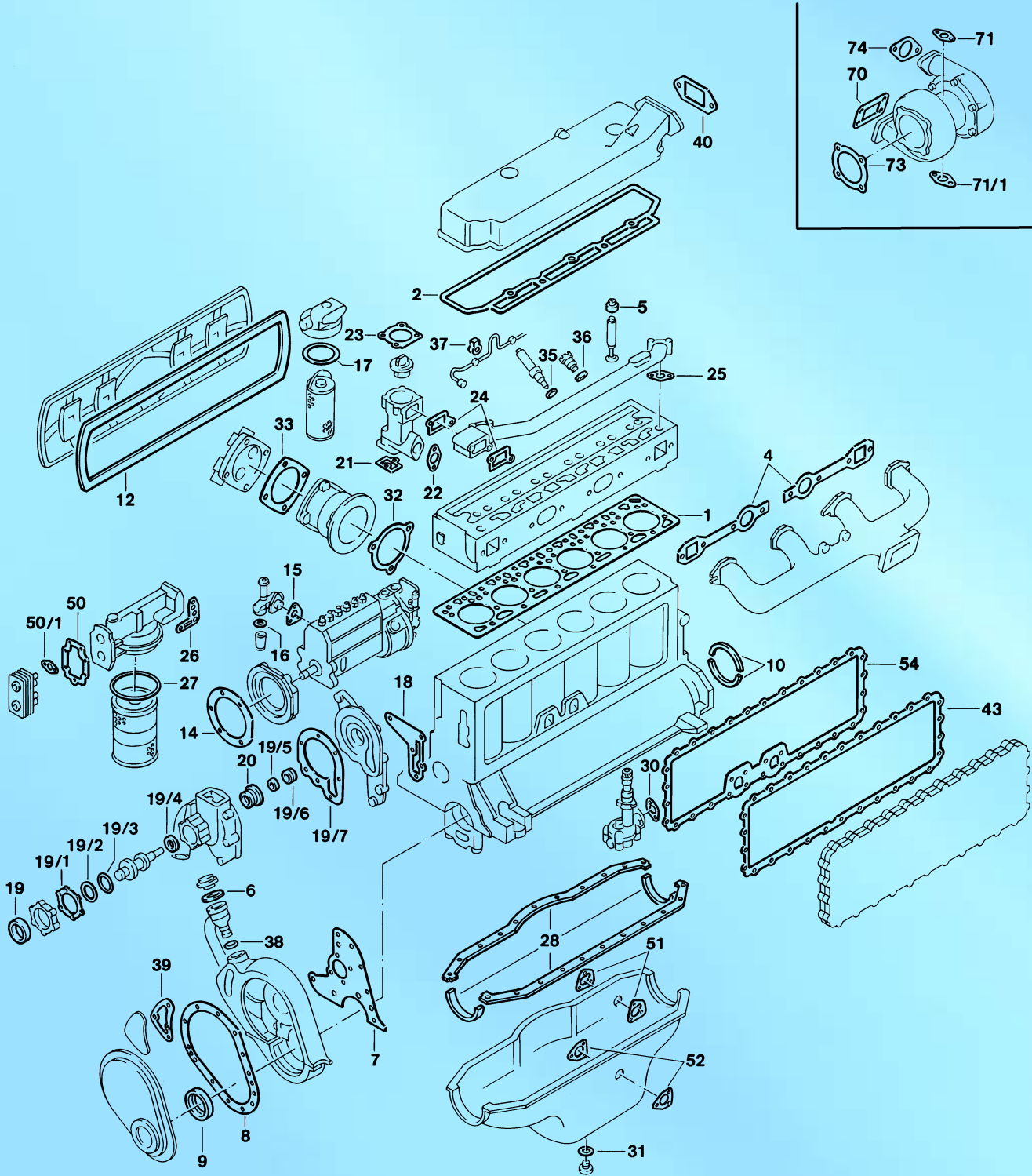
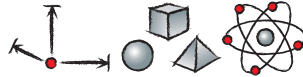

S *	826.936	1x	-	-	-	-> Mot. 760548
S *	826.944	1x	-	-	-	Mot. 760549 ->
ES	813.842	1x	352 010 26 21	-	-	-
CS *	817.503	1x	353 010 47 08	-	-	-> Mot. 598249
CS *	817.538	1x	353 010 49 08	-	-	Mot. 598250 -> Mot. 760548
CS *	817.511	1x	353 010 48 08	-	-	Mot. 760549 ->
OKS	813.818	1x	352 180 25 65	-	-	-> Mot. 730880
OKS	828.181	1x	352 180 37 65	-	-	Mot. 730881 ->
ZKS	820.075	1x	-	-	-	-
1	760.678	1x	366 016 06 20	-	-	-
2	777.773	1x	352 016 09 21	-	-	-
4	522.929	2x	352 142 04 80	-	-	-
5	325.813	6x	352 053 02 96	9x14,6/19x14 ACM PR	-	-> Mot. 794938 E
5	577.898	6x	366 053 00 58	9x14,6/19x15 FPM PR	-	Mot. 794939 -> E
5	468.045	6x	360 053 00 96	10x14,6/19x14 ACM PR	-	-> Mot. 794938 A
5	577.901	6x	366 053 01 58	10x14,6/19x15 FPM PR	-	Mot. 794939 -> A
6	a.A.	1x	352 018 01 80	37x59,5x3	-	-> Mot. 462952
6	827.428	1x	102 018 03 80	38,5x59x2,3 HNBR A	-	Mot. 462953 ->
7	977.160	1x	366 015 01 80	-	-	-
8	184.268	1x	352 015 03 20	-	-	-> Mot. 598249
8	768.804	1x	366 015 00 20	-	-	Mot. 598250 ->
9	283.983	1x	009 997 77 47 009 997 94 47 006 997 85 47	B RD LA FPM 65x90x15	-	-> Mot. 598249
9	553.272	1x	014 997 16 47	AW/BS RD FPM 65x90x12	-	Mot. 598250 ->
10	101.577	2x	001 997 31 41	-	-	-
12	748.498	1x	352 015 05 22	-	-	-
14	112.802	1x	352 076 02 80	-	-	-
15	a.A.	1x	001 074 22 80	-	-	-
16	716.200	1x	000 997 00 40	28x36x2 NBR A	-	-
17	733.431	1/2x	000 477 31 80	-	-	-
17	731.269	1/2x	000 477 35 80	-	-	-
18	777.919	1x	352 201 20 80	-	-	Mot. 352.913/916/918/937/946/949/ 950/968/988/994 Mot. 353.911-914 -> Mot. 000846
18/1	777.900	1x	352 201 16 80	-	-	Mot. 352.913/916/918/937/946/949/ 950/968/988/994 Mot. 353.911-914 Mot. 000847 ->
18/1	777.900	1x	352 201 16 80	-	-	Mot. 353.911-914 -> Mot. 760548
18/3	775.991	1x	352 201 19 80	-	-	Mot. 353.909/910/952/953
18/3	775.991	1x	352 201 19 80	-	-	Mot. 353.950/951/954/970-975/ 978/997 -> Mot. 760548
18/4	775.534	1x	352 201 17 80	-	-	Mot. 353.911-914 Mot. 760549 ->
18/5	768.033	1x	366 201 04 80	-	-	Mot. 353.950/951/954/970-975/978/ 997 Mot. 760549 -> Mot. 353.991
19	344.400	1x	003 997 51 46 005 997 00 47	A NBR 42x56x7	-	-
19/1	827.096	1x	352 201 21 80	-	-	-> Mot. 000379
19/2	a.A.	1x	352 201 22 80	-	-	Mot. 000380 ->
19/3	a.A.	1x	005 997 11 45	62x68x3 NBR RD	-	Mot. 000380 ->
19/4	054.003	1x	002 997 84 46 005 997 01 47	A NBR 17x35x7	-	-
19/5	a.A.	1x	000 201 04 63	-	-	-

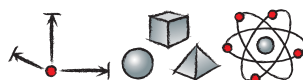

19/6	190.608	1x	000 201 01 97	-	-
19/7	768.961	1x	364 201 02 80	-	-
20	577.804	1x	000 201 92 19	-	-
21	777.782	1x	352 203 23 80	-	-
22	775.673	1x	917003 022003	-	-
23	811.808	1x	352 203 20 80	-	-> Mot. 437435
23	777.811	1x	352 203 22 80	-	Mot. 437436 ->
24	777.804	2x	352 203 24 80	-	-
25	768.988	2x	366 203 03 80	-	-
26	a.A.	1x	366 184 00 80	-	Mot. 353.911-913/950/951/975/975 -> Mot. 923826
26/1	a.A.	1x	364 184 02 80	-	-
27	774.057	1x	000 184 65 80	115x125,2x5,1 NBR RD	-
27	305.308	1x	006 995 25 48	101x109,6x4,3 NBR RD	-
27	780.103	1x	008 997 70 45	132x142x4 NBR RD	-
28	284.734	1x	366 010 06 80	-	-
28	-	1x	366 010 06 80	einteilig single-piece mono pièce monopieza in un pezzo unico из одной части	-
30	a.A.	1x	312 186 00 80	-	-
31	813.168	1x	915035 000029	24x32x2,5 DIN 7603 CUW C	-> Mot. 407131
31	031.046	1x	007603 026109	26x34x2 DIN 7603 CU A	Mot. 407132 ->
32	775.950	1x	321 131 00 80	0,25 mm (77 mm Ø Cyl.)	-> Mot. 470359
32	775.968	1x	321 131 01 80	0,5 mm (77 mm Ø Cyl.)	-> Mot. 470359
32	768.863	1x	366 131 02 80	0,65 mm (94 mm Ø Cyl.)	Mot. 470360 ->
32	768.871	1x	366 131 01 80	0,9 mm (94 mm Ø Cyl.)	Mot. 470360 ->
33	776.041	1x	352 131 06 80	1,0 mm (77 mm Ø Cyl.)	-> Mot. 470359
33	768.863	1x	366 131 02 80	0,65 mm (94 mm Ø Cyl.)	Mot. 470360 ->
33	768.871	1x	366 131 01 80	0,9 mm (94 mm Ø Cyl.)	Mot. 470360 ->
35	a.A.	6x	388 017 01 60	1 mm	-
35	067.989	6x	346 017 02 60	1,5 mm	-
36	776.262	6x	016 997 82 48	30,8x38,2x3,7 FPM RD	-
37	175.811	6x	352 078 00 80	-	-
38	a.A.	1x	006 997 46 45	28x32x2 NBR RD	Mot. -> 0429439
38	a.A.	1x	000 997 13 48	27x32x2,5 NBR RD	Mot. 0429440 ->
39	a.A.	1x	352 015 03 80	-	-
40	a.A.	1x	352 016 03 80	-	-
43	775.657	1x	366 188 02 80	-	-
50	-	1x	355 188 01 80	-	-
50/1	777.846	1x	364 184 03 80	-	-
51	-	2x	366 018 02 80	-	-
52	-	2x	366 018 05 80	-	-
54	811.777	1x	352 188 08 80	-	-> Mot. 730880
54	829.773	1x	366 188 05 80	-	Mot. 730881 ->
70	776.025	1x	312 096 01 80	-	Mot. 352.913
70	308.994	1x	352 098 02 80	-	-
71	756.874	1x	442 187 01 80	-	-
71/1	756.866	1x	442 187 00 80	-	-
73	017.264	1x	352 098 09 80	-	-
74	-	1x	352 098 05 80	-	-